

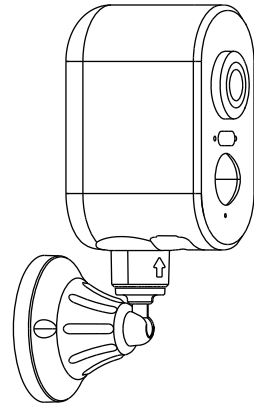

See Everthing, Miss Nothing

We hope you never have the need
but if you do our service is friendly and hassle-free.

✉ support@czeview.net



Battery-Powered Wireless Camera User Manual

Technical Support

For assistance, please contact the CZEview Customer Service Centre before returning the product. Most issues can be resolved via our after-sales email at support@czeview.net, and we will respond within 24 working hours.

Alternatively, scan the QR code below to contact us.

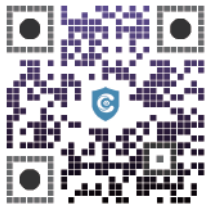

Quick Start

Scan the QR code below to quickly access the tutorial video guide,



or refer to the [Quick Start Card or Manual's contents page](#) for detailed instructions.

IMPORTANT TIPS

Due to product updates, the user manual will be regularly revised. Scan the QR code below for the latest version.



CONTENTS

IMPORTANT SAFETY INSTRUCTIONS	P01
BATTERY	P02
CAUTIONS	P02
WHAT'S INCLUDED	P03
PRODUCT OVERVIEW	P04
SPECIFICATIONS	P05
STORAGE METHODS	P06
INSTALL THE CAMERA	P06

IMPORTANT SAFETY INSTRUCTIONS

- Ensure adherence to all warnings and instructions marked on the product.
- Employ only attachments and accessories endorsed by the manufacturer.
- Please turn off the power when the device is not in use for an extended period.
- Charge the battery-powered camera using the specified power source indicated on the product. Do not use solar panels from other brands to charge the battery.
- Do not attempt to disassemble. Contact authorized service facilities for maintenance.
- Supervise children to prevent product tampering.
- Store small, detachable parts away from young children to prevent choking hazards.
- Not for use by individuals with limited physical, sensory, or mental capabilities without proper supervision.
- Ensure that the solar panel receives enough sunlight and avoid obstructions (such as trees, buildings, or other objects) that could block the light
- The surface of the solar panel may accumulate dust, dirt, or fallen leaves, which can affect light absorption. It is recommended to clean the panel regularly, usually every few months

BATTERY

- The battery is built-in. Do not attempt to remove it from the camera.
- Charge the battery at temperatures between 0°C and 45°C, and use the battery at temperatures between -20°C and 50°C.
- Keep the charging port dry, clean, and free of debris. Cover it with the rubber cap when the battery is not charging.
- Do not charge, use, or store the battery near ignition sources, such as open flames or heaters.
- Do not use the battery if it emits an odor, generates heat, changes color, becomes deformed, or shows any signs of abnormality. If the battery is currently in use or charging, stop immediately and contact the brand seller for after-sales service.
- Avoid exposure to extreme temperatures and pressures, which can cause explosions or leaks.
- Do not dispose of the battery in fire or attempt to damage it mechanically.
- Follow proper disposal guidelines for used batteries to minimize environmental harm.

CAUTIONS

- Handle batteries with care to avoid burn, fire, and explosion hazards.
- Protect the product from extreme temperatures, sunlight, and heat sources.
- Prevent strangulation by keeping cords out of children's reach.
- Be mindful of potential interference from other electronic devices and position the camera unit accordingly.

WHAT'S INCLUDED



CZeview Camera



Mounting Bracket



Screw Pack



Power Cord



User Manual



Magnetic Base



Adhesive



Quick Start Guide

PRODUCT OVERVIEW

• Battery-Powered Camera

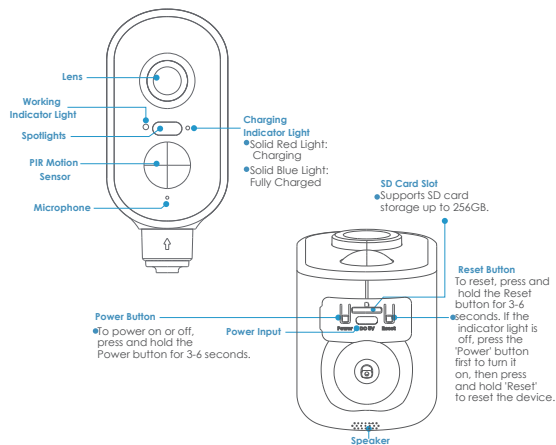

Working Indicator Light

Solid Red Light	<ul style="list-style-type: none"> ● Device error detected (Please reset and reconnect to the network)
Slow Red Flash	<ul style="list-style-type: none"> ● Wi-Fi pairing mode activated, awaiting connection
Fast Red Flash	<ul style="list-style-type: none"> ● Searching for Wi-Fi networks
Solid Blue Light	<ul style="list-style-type: none"> ● Camera functioning normally
Slow Blue Flash	<ul style="list-style-type: none"> ● Connecting to Wi-Fi
Fast Blue Flash	<ul style="list-style-type: none"> ● Device is upgrading
Alternating Red and Blue Lights	<ul style="list-style-type: none"> ● Connection timed out. Long press Power for 3-6s to turn off, then power on and retry Wi-Fi connection.

SPECIFICATIONS

RESOLUTION	3MP 2K
BATTERY CAPACITY	5200MAH
WIFI BAND	2.4G
TWO-WAY AUDIO	SUPPORTED
SIREN ALARM	SUPPORTED
SPOTLIGHT ALARM	SUPPORTED
MOVEMENT DETECTION	SUPPORTED
COLOR NIGHT VISION	SUPPORTED
PAN/TILT	PAN 300°
WATERPROOF RATING	IP65
OPERATING TEMPERATURE	-4 ℱ - 122 ℱ
LOCAL STORAGE	MICRO SD CARD (UP TO 256G)
POWER SUPPLY (NOT INCLUDED)	DC 5V/2A

STORAGE METHODS

• LOCAL MONITORING

A Micro SD card (up to 256GB, NOT INCLUDED) is required for recording and storage. It is optional if video and image storage isn't needed.

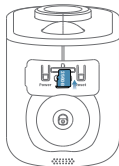

• CLOUD STORAGE OPTIONS

Choose a cloud storage plan for video clips, providing additional backup and features. Subscription is available after the device is connected in the app.

INSTALL THE CAMERA

1. CHARGE THE CAMERA

For first-time use, please fully charge the camera. When the indicator light turns solid blue, the camera is fully charged.

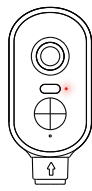
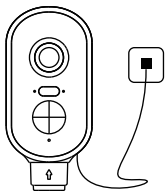

Charging



Fully Charged

! Note:

To maintain weatherproof performance, always cover the charging port with the rubber cap after charging the camera.

2. Choose the mounting method for the bracket.

A. Using the Magnetic Base

- Attach the mounting bracket with the camera to the flat, magnet-friendly surface where you plan to install the camera.

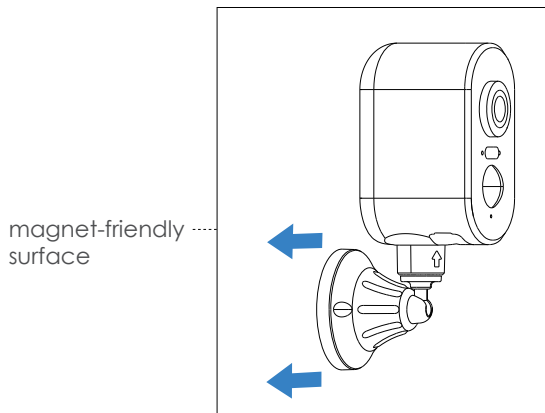

B. Using Adhesive

- Ensure the surface is flat and clean.
- Apply the adhesive to both the surface and the magnetic base.
- Press firmly for better adhesion, and wait 8 hours before mounting the camera. Avoid exposing the adhesive to rain.
- Attach the mounting bracket with the camera to the magnetic base.

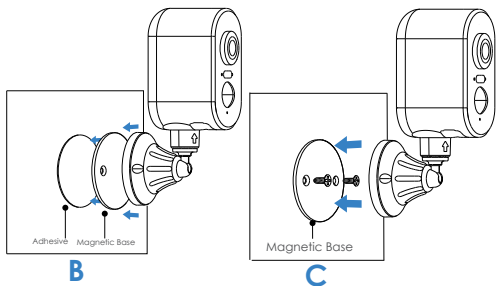

C. Using Screws

- Secure the magnetic base to a flat surface with screws.
- Attach the mounting bracket with the camera to the magnetic base.

D. Placing on a Flat Surface

- Simply place the camera on a flat tabletop.

! Note:

Keep fingers clear of the magnet when assembling to avoid pinching or injury.

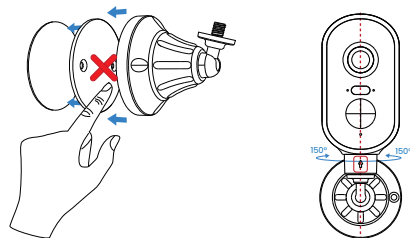

3. Make sure the arrow symbol is aligned with the center of the camera.

This allows the camera to move horizontally, 150° to the left and 150° to the right.

4. Install the solar panel.

Mount the solar panel on the wall separately. Adjust the panel's angle to ensure direct sunlight exposure for maximum absorption.

5. Connect the solar panel cable to the camera's input port.

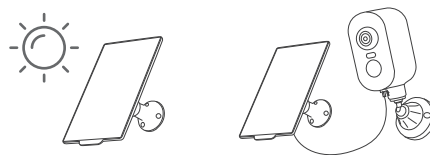

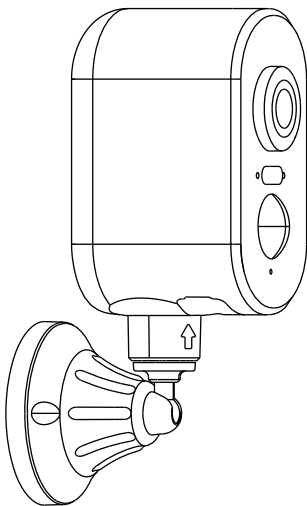

Battery-Powered Wireless Camera User Manual

SET UP THE CAMERA ON THE APP P01
METHOD 2 SCAN QR CODE

APP FUNCTIONS P05

TROUBLESHOOTING P14

SET UP THE CAMERA ON THE APP

• II. METHOD 2 SCAN QR CODE

1. On the 'Home' page, tap 'Add' or  in the upper right corner to add a device.
2. Choose the correct type and model for your device from the list.

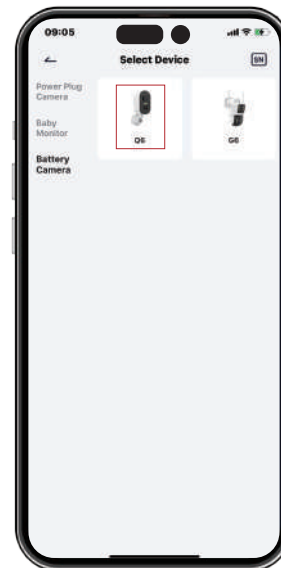
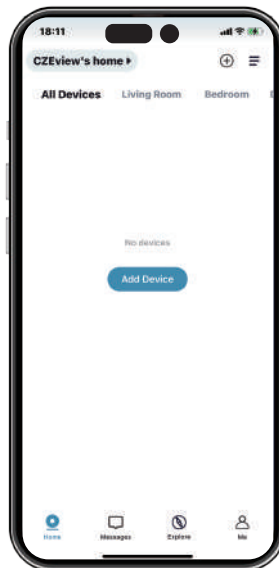

3. Follow the on-screen instructions, and tap 'Next'.

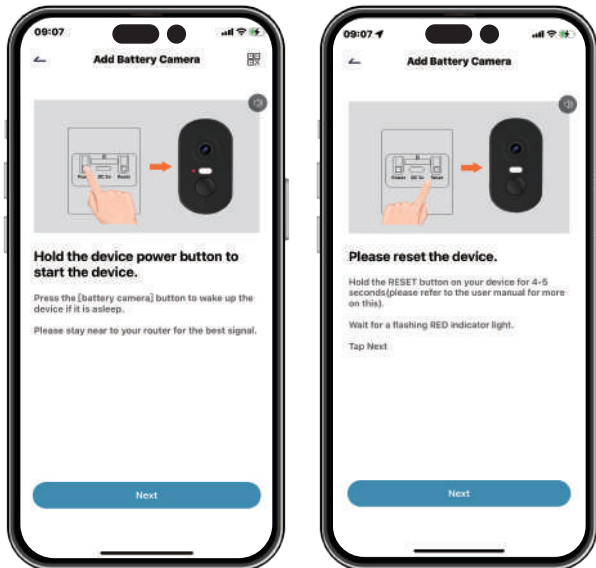

4. Select the same WiFi network your phone is connected to and enter the correct password.
5. Remove the film from the lens and ensure it is clean and free of dirt. After confirming the lens is clear, tap 'Next' to generate a QR code.

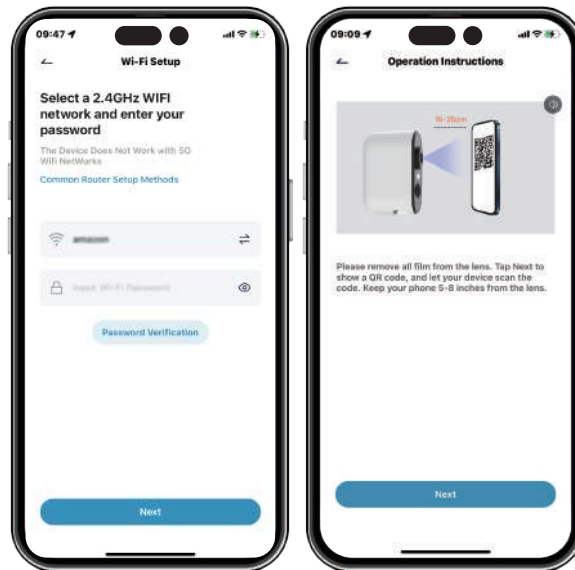

6. Hold the QR code 5–8 inches from the lens, directly in front of it, and scan. Listen for a 'cuckoo' sound, which indicates the connection process has begun. After this, tap 'Next'.

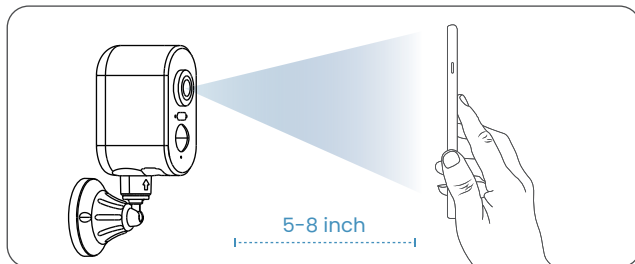

7. Confirm that the indicator light turns to a steady blue, indicating a successful setup. Following this, press 'Next' to assign a name to your camera.

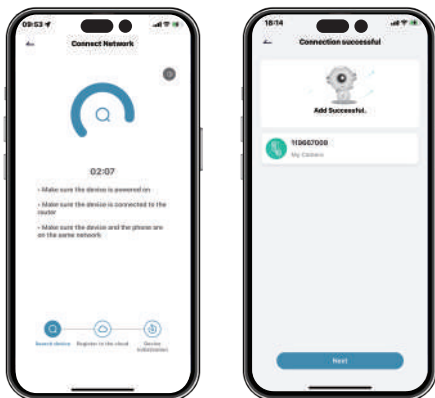

APP FUNCTIONS

• ADJUST VIDEO DEFINITION

1. In the video preview window on the Home page, click ▶ to enter the live view.
2. Click the drop-down menu in the lower right corner of the video window.
3. Choose from the available video definition levels.

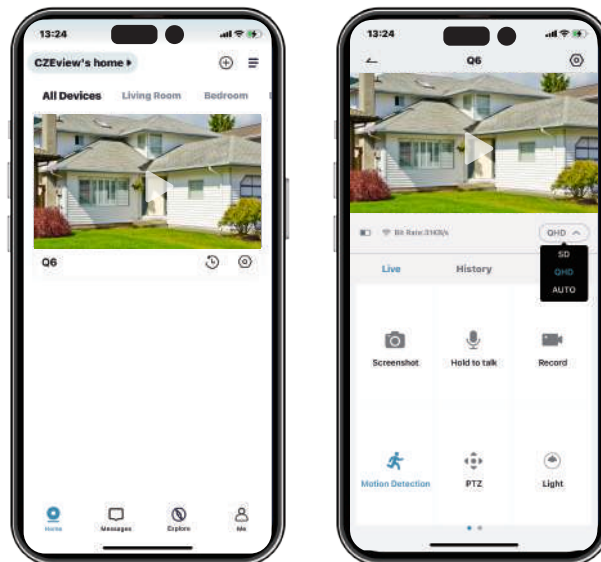

• ADJUST LENS ORIENTATION

1. In the live video window, locate the 'PTZ' button.
2. Use this feature to adjust the lens and monitor in horizontal directions.

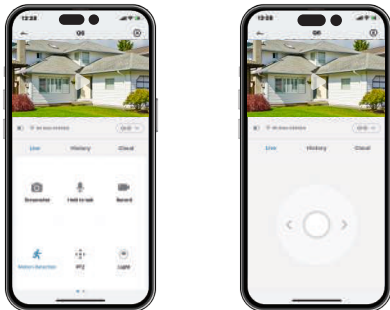

• IMAGE SETTINGS

1. On the Home page, find your device and tap the  icon in the lower right corner of the window.
2. Tap 'Image Settings'.
3. Choose your preferred Screen Orientation and Night Vision Mode.

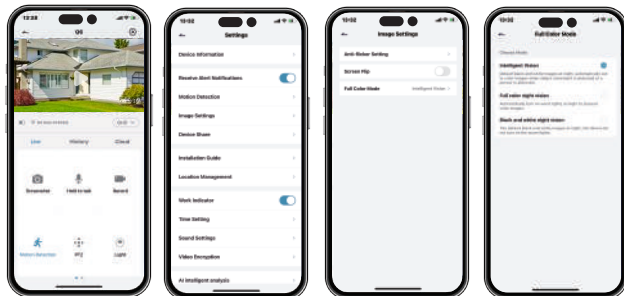

• MANAGE ALARMS

Note:

Before setting up 'Alarm Management,' please confirm your storage method: SD card, paid cloud storage, or free basic cloud storage. The storage type influences the format of alarm records you receive (some will be videos, others will be images) and the availability of videos may vary:

1. SD Card Storage: Alarm records will be saved as 10-second videos in Alarm Messages. (You can adjust the recording duration in the 'Motion Detection' settings.)
2. Paid Cloud Storage: Alarm records will also appear as 10-second videos in Alarm Messages. (Similar to SD card storage, the recording duration can be modified in 'Motion Detection'.)
3. Free Cloud Storage: Alarm records will be 6-second videos in Alarm Messages. (The recording duration is fixed and cannot be changed.)
4. No Cloud Storage or SD Card: In this case, alarm records will be displayed as images in Alarm Messages.

1. On the Home page, locate your device and tap the  icon at the lower right corner of the window.

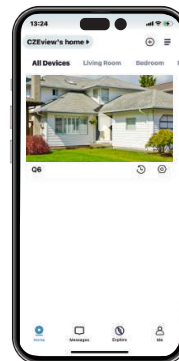

2. Navigate to 'Motion Detection':

- Motion Detection: Enable this feature to receive notifications according to your preferences. You can customize settings such as 'Detection Sensitivity,' 'Humanoid Detection,' 'Working Mode,' 'Alert Plan,' 'Humanoid Alarm Area,' and 'Audio Warning and Strobe Light.'

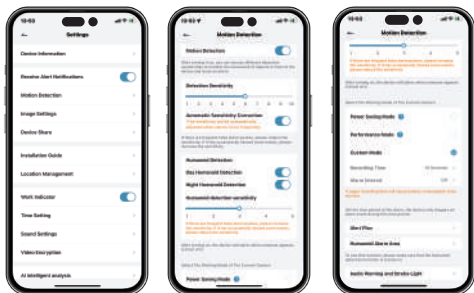

- Set up Alarm Siren and Spotlight: Enable this feature to activate the Alarm Siren and Spotlight.

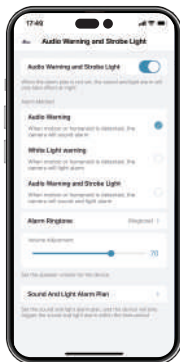

Note:
The Alarm Siren and Spotlight will only be triggered in low-light or dark conditions.

• INTERCOM

1. In the live video window, locate the 'Hold to Talk' button and press it to start speaking.

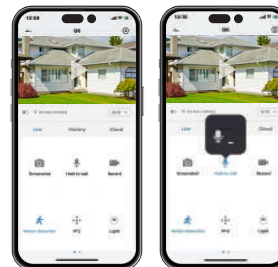

• SHARING THE CAMERA WITH FAMILY

1. On the Home page, find the device you want to share and tap the  icon in the lower right corner of the window.
2. Select 'Device Share'.
3. For a quick setup, watch the video guide, then tap 'Add'.
4. Choose 'Scan QR Code' or 'Enter Account' to send an invitation.

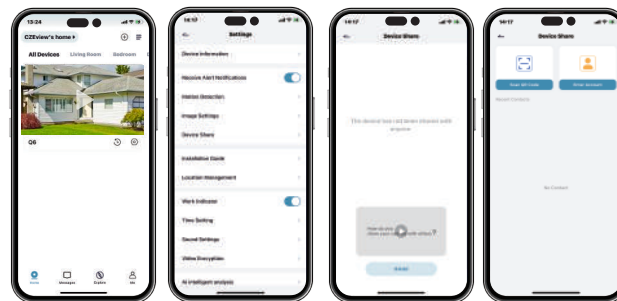

5. If using a QR code:

- Open the app on the invitee's phone.
- Tap 'Me' in the bottom navigation bar.
- Click on the avatar and select 'My QR Code'.

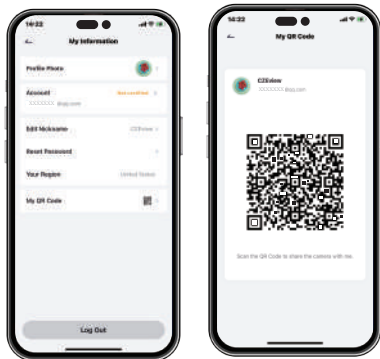

6. After scanning the QR code or entering the email address, set the permissions for the invitee in your app.

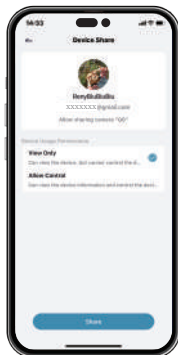

7. The invitee will receive a confirmation notification in their app.

8. After the invitee accepts the invitation for device sharing, their information will appear in the 'Device Share' section of your app.

9. The shared device will then show up on the invitee's app home page.

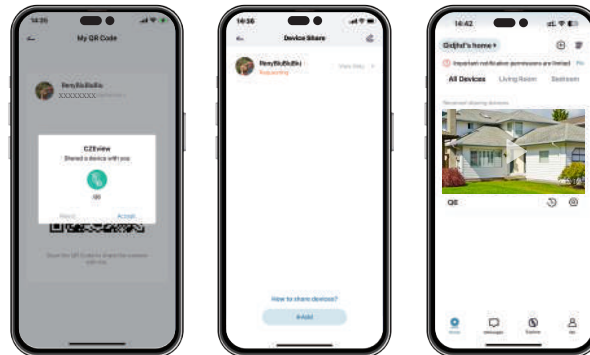



• HOW TO DELETE THE INVITEE

1. On the Home page, locate the device you have shared and tap the  icon in the lower right corner of the window.

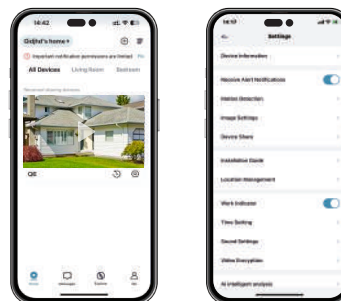
2. Select 'Device Share'.



- Click the  icon in the upper right corner, then tap the DELETE icon . A confirmation prompt will appear.

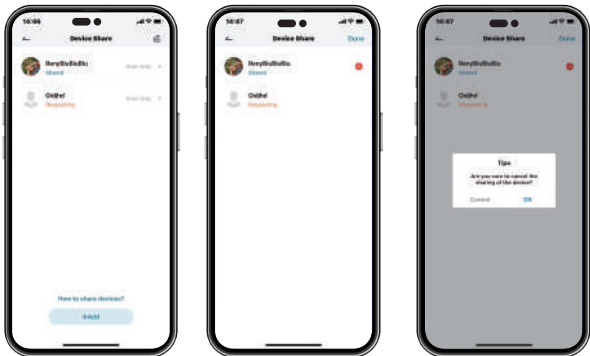

- The invitee will receive a notification in their app indicating that they have been removed from the shared device list.



• AI INTELLIGENT ANALYSIS

- On the Home page, find your device and tap the  icon in the lower right corner of the window.
- Select 'AI Intelligent Analysis'.
- Once purchased, this feature can recognize humans, pets (limited to cats and dogs), vehicles, and packages.

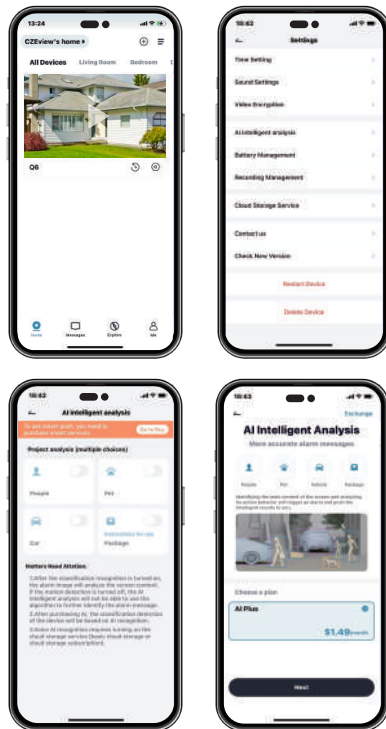

TROUBLESHOOTING

EN

•Q1. Why can't the camera connect to the APP

- * Ensure the camera is powered on, indicated by a slow red flashing light. If the indicator light flashes alternately between red and blue, the connection has timed out. In this case, press and hold the 'Power' button for 3-6 seconds to turn the camera off, then power it back on and try reconnecting to Wi-Fi. If the indicator light is off, press the 'Power' button briefly to wake the camera, then hold the 'Reset' button for 3-6 seconds and attempt to reconnect to Wi-Fi.
- * Verify that the 'CZView' app is installed on your device.
- * Make sure to select the correct device type and model when adding a new device in the app.
- * Check for a stable network connection and ensure both the camera and your mobile device are close to the router during setup.
- * Enter the correct password as specified in the instruction manual.
- * Avoid using emojis, special characters, or symbols in your Wi-Fi name or password.
- * If the above steps do not resolve the issue, press and hold the 'Reset' button on the camera until you hear a 'cuckoo' sound. This will initiate recalibration. Afterwards, reconnect the camera in the app. Note that the camera can only be reset when the indicator light is on. If the camera has entered sleep mode and the indicator light is off, press the 'Power' button briefly to wake it, then perform the reset.
- * If the problem persists, please contact our support team at support@czeview.net.

•Q2. Why can't the camera scan the QR code when connecting to the app?

- * If the camera's indicator light is rapidly flashing red: a. Ensure the router is functioning correctly and emitting a strong signal. b. Check the stability of the network. c. Make sure the device is not in a location without network coverage. d. If the problem continues, press and hold the 'RESET' button until you hear a 'cuckoo' sound. This will initiate the recalibration process. Once the recalibration is complete and the indicator light begins flashing red slowly, try reconnecting. Note: The camera can only be reset when the indicator light is on. If the camera is in sleep mode and the indicator light is off, briefly press the 'Power' button to wake it, then perform the reset.
- * If the camera's indicator light is slowly flashing red: a. Clean the lens if it appears dirty. b. Move the camera to an area with less bright lighting if needed.
- * If these steps do not solve the problem, please contact our support team at support@czeview.net for further assistance.

•Q3. What should I do if the device shows as offline?

- * Confirm that the camera is powered on and that the indicator light is functioning as expected.
- * Verify that the Wi-Fi network is stable, and restart the router if necessary.
- * If the device is too far from the router to receive a strong Wi-Fi signal, consider moving the router closer or using a Wi-Fi extender to enhance signal strength.
- * Remove the Q6 camera from your 'CZView' account, reset the device, and add it again.
- * Ensure both the device firmware and the app are up to date.
- * If these steps do not resolve the issue, please contact our support team at support@czeview.net for further assistance.

EN

• Q4. Why didn't I receive the alarm messages?

- * On the Home page, locate your device and tap the  icon in the lower right corner. Then, select 'Motion Detection' and ensure that the 'Motion Detection' feature is enabled.
- * In the same settings section of the app, verify that 'Receive Alert Notifications' is turned on.
- * Check your phone's system settings to confirm that the app has permission to send push notifications for motion detection.
- * If these steps do not solve the issue, please contact our support team at support@czeview.net for further assistance.

• Q5. How can I reduce unnecessary false alarms?

- * Avoid placing the camera in the direction of bright lights, such as sunlight or bright lamps.
- * Do not aim the camera lens directly at roads; it is best to keep the camera at least 10 meters away from driveways or streets.
- * Ensure the camera is not positioned near sources of air flow or heat, like air conditioner vents, humidifiers, or projector heat vents.
- * Avoid setting up the camera to face mirrors or glass surfaces.
- * Keep the camera at least 1 meter away from any wireless devices, including Wi-Fi routers, to minimize interference.

• Q6. How do I reconnect the device in a new Wi-Fi area?

- * On the Home page, locate your device and tap the  icon in the lower right corner. Scroll to the bottom and select 'Delete Device.'
- * Press and hold the 'RESET' button until you hear a 'cuckoo' sound to initiate the recalibration process. Note: The camera can only be reset when the indicator light is on. If the camera is in sleep mode and the indicator light is off, briefly press the 'Power' button to wake it, then perform the reset.
- * Once recalibration is complete and the indicator light starts flashing red slowly, reconnect the device to the app using the new Wi-Fi signal.

• Q7. Why can't the SD card be recognized by the camera?

1. Tap the  icon located in the lower right corner of the window.
2. Go to 'Recording Management'. If the SD card's memory information is not displayed, try these troubleshooting steps:
 - a. Turn off the camera, remove the SD card, and reinsert it with the label side facing up and the pins facing down. Then, power the camera back on and check if the app can read the SD card's memory information.
 - b. Check if the SD card's information can be read by a computer. If the SD card is not recognized by the computer, it may need to be replaced. If the card can be read, please contact our support team at support@czeview.net for further assistance.
 - c. If these steps do not resolve the issue, feel free to reach out to our support team at support@czeview.net.

• Q8. How do I seek seller support for assistance?

- * Open the CZView app and go to 'Me' at the bottom of the navigation bar. Tap 'Help' > 'Feedback' > 'Send us feedback'. Here, you can request assistance and provide the necessary details.
- * Alternatively, you can directly email us at support@czeview.net with your concerns.